

SD331-Q170

Desktop

Q170

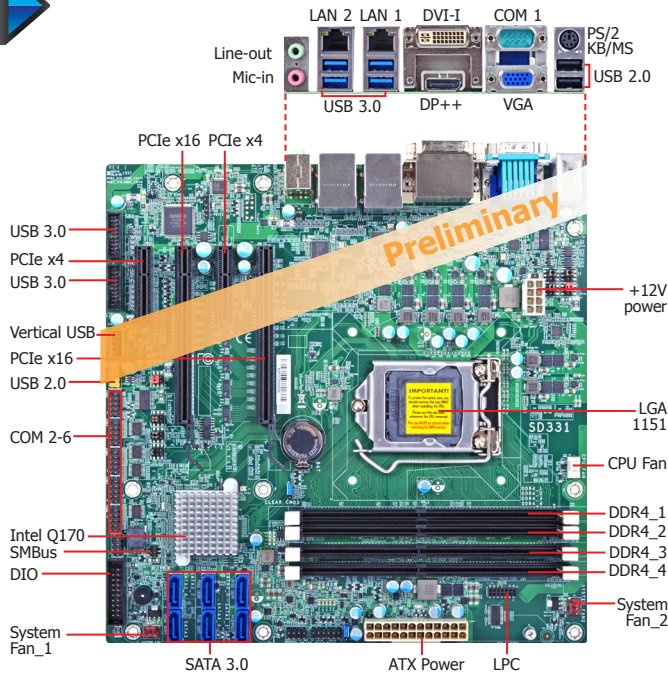

Preliminary

Features

- 4 DDR4 DIMM up to 64GB
- Three independent displays: VGA + DVI-I + DP++
- DP++ resolution up to 4096x2304 @ 60Hz
- Multiple expansion: 2 PCIe x16 (1 x16 or 2 x8 signal), 2 PCIe x4, 1 LPC
- Rich I/O: 2 Intel GbE, 6 COM, 8 USB 3.0, 5 USB 2.0
- LPC EXT-RS232/485 module extends additional 4 COM ports



2 Extension Modules for Additional 4 COM Ports (via the LPC connector)

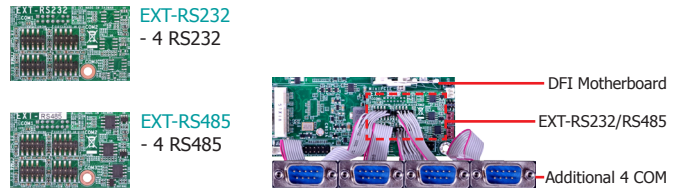

Ordering Information

Model Name	P/N	Memory	GbE	RS-232/422/485	RS-232	USB 3.0	USB 2.0	Power	Thermal	Temp.
SD331-Q170	770-SD3311-000G	4 DIMM	2	2	4	8	5	24-pin ATX	Active	0 to 60°C

Mechanical Drawing



Block Diagram

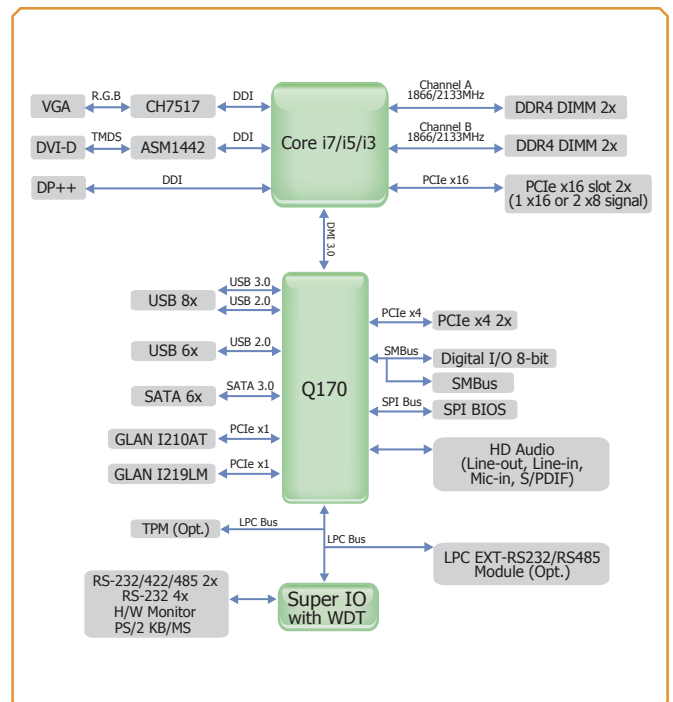

Specifications

SYSTEM	Processor	6th Generation Intel® Core™ Processors, LGA 1151 Socket Intel® Core™ i7-6700 Processor, Quad Core, 8M Cache, 3.4GHz (4.0GHz), 65W Intel® Core™ i7-6700TE Processor, Quad Core, 8M Cache, 2.4GHz (3.4GHz), 35W Intel® Core™ i5-6500 Processor, Quad Core, 6M Cache, 3.2GHz (3.6GHz), 65W Intel® Core™ i5-6500TE Processor, Quad Core, 6M Cache, 2.3GHz (3.3GHz), 35W Intel® Core™ i3-6100 Processor, Dual Core, 4M Cache, 65W Intel® Core™ i3-6100TE Processor, Dual Core, 4M Cache, 2.7GHz, 35W (ECC Supported) Intel® Pentium® Processor G4400, Dual Core, 3M Cache, 3.3GHz, 65W Intel® Pentium® Processor G4400TE, Dual Core, 3M Cache, 2.9GHz, 35W Intel® Celeron® Processor G3900, Dual Core, 2M Cache, 2.8GHz, 65W Intel® Celeron® Processor G3900TE, Dual Core, 2M Cache, 2.6GHz, 35W	
	Chipset	Intel® Q170 Chipset	
	Memory	Four 288-pin DIMM up to 64GB	Dual Channel DDR4 1866/2133MHz
	BIOS	Insyde SPI 128Mbit	
GRAPHICS	Controller	Intel® HD Gen 9 Graphics	
	Feature	OpenGL 5.0, DirectX 12, OpenCL 2.1 HW Decode: AVC/H.264, MPEG2, VC1/WMV9, JPEG/MJPEG, HEVC/H265, VP8, VP9 HW Encode: MPEG2, AVC/H264, JPEG, HEVC/H265, VP8, VP9	
	Display	1 x VGA 1 x DVI-I (DVI-I-D signal) 1 x DP++	VGA: resolution up to 1920x1200 @ 60Hz DVI-I: resolution up to 1920x1200 @ 60Hz DP++: resolution up to 4096x2304 @ 60Hz
	Triple Displays	VGA + DVI-I (DVI-D signal) + DP++	
EXPANSION	Interface	2 x PCIe x16 (1 x16 or 2 x8 signal) (Gen 3) 2 x PCIe x4 (Gen 3)	
AUDIO	Audio Codec	Realtek ALC888S-VD2-GR	
ETHERNET	Controller	1 x Intel® I210AT PCIe (10/100/1000Mbps) 1 x Intel® I219LM PCIe with iAMT11.0 (10/100/1000Mbps) (only Core i7/i5 supports iAMT)	
REAR I/O	Ethernet	2 x GbE (RJ-45)	
	USB	4 x USB 3.0 2 x USB 2.0	
	Serial	1 x RS-232/422/485 (RS-232 w/ power) (DB-9)	
	PS/2	1 x PS/2 (mini-DIN-6)	
	Display	1 x VGA 1 x DVI-I (DVI-D signal) 1 x DP++	
	Audio	1 x Line-out, 1 x Mic-in, 1 x Line-in (available upon request)	
	INTERNAL I/O	Serial	1 x RS-232/422/485 (RS-232 w/ power) (2.54mm pitch) 4 x RS-232 (2.54mm pitch)
USB		4 x USB 3.0 (2.00mm pitch) 2 x USB 2.0 (2.54mm pitch) + 1 x Vertical USB 2.0 (type A) or 4 x USB 2.0 (2.54mm pitch, available upon request)	
Audio		1 x Audio (Line-out/Mic-in) (available upon request) 1 x S/PDIF	
SATA		6 x SATA 3.0 (up to 6Gb/s)	RAID 0/1/5/10
DIO		1 x 8-bit DIO	
LPC		1 x LPC (supports LPC EXT-RS232/RS485 module)	
SMBus		1 x SMBus	
WATCHDOG TIMER		Output & Interval	System Reset, Programmable via Software from 1 to 255 Seconds
SECURITY	TPM	Available Upon Request	
POWER	Type	ATX	
	Connector	8-pin ATX 12V power	24-pin ATX power
	Consumption	TBD	
	RTC Battery	CR2032 Coin Cell	
OS SUPPORT		Windows 7 (WES7) 32/64-bit Windows 8.1 (64-bit) Windows 10 IoT Enterprise 64-bit	Debian 8 (with VESA graphic driver) CentOS 7 (with VESA graphic driver) Ubuntu 15.10 (Intel graphic driver available)
ENVIRONMENT	Temperature	Operating: 0 to 60°C	Storage: -40 to 85°C
	Humidity	Operating: 5 to 90% RH	Storage: 5 to 90% RH
	MTBF	374,618 hrs @ 25°C; 211,926 hrs @ 45°C; 133,291 hrs @ 60°C Calculation Model: Telcordia Issue 2, Method Case 3 Environment: GB, GC – Ground Benign, Controlled	
MECHANICAL	Dimensions	microATX form factor 244mm (9.6") x 244mm (9.6")	
	Height	PCB: TBD	Top Side: TBD, Bottom Side: TBD

Packing List

• 1 SD331-Q170 motherboard	
• 1 COM port cables (Length: 260mm)	332-054028-004G
• 1 Serial ATA data cable (Length: 500mm)	332-553001-005G
• 1 I/O shield	A49-SD3300-000G
• 1 DVD	

Optional Items

• USB 2.0 port cable (Length: 350/398mm)	332-253010-026G
• USB 3.0 port cable (Length: TBD)	TBD
• COM port cable (Length: 260mm)	332-054028-004G
• Serial ATA data cable (Length: 500mm)	332-553001-005G
• Thermal solution (For 35W, Height: 37.3mm)	A71-103004-000G
• Thermal solution (For 65W, Height: 72.8mm)	552-200049-000G
• Thermal solution (For 95W, Height: 69.3mm)	761-103001-000G
• LPC EXT-RS232 module (4 x RS232 ports)	770-EXTRS1-000G
• LPC EXT-RS485 module (4 x RS485 ports)	770-EXTRS1-100G