



Travla Series
Model : C158
2.1" x 12" x 11" (HxWxL)
QUICK START
USER GUIDE

WARNING: Installation and service of this product should only be performed by qualified personnel to avoid damage to this product and risk of injuries.

- Included accessories:
1. Mounting Kit - 1 Pair
 2. Single PCI riser card - 1 pcs
 3. Screw accessories - 1 bag

Screw Identification Guide

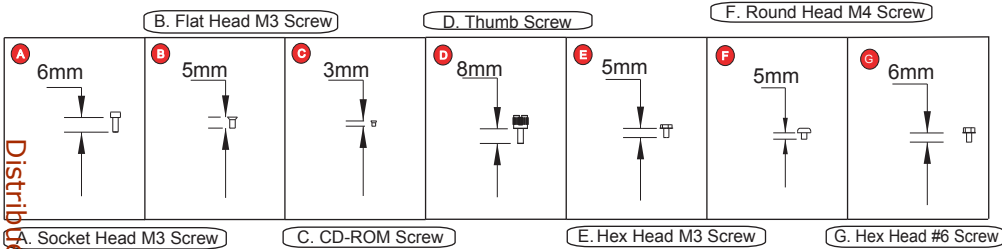

Distributeur par Anteor - www.anteor.com - Tél : 01 61 37 07 00

1. Remove Top Cover

1. Loosen screw "D" (x1)
2. Slide back Top Cover

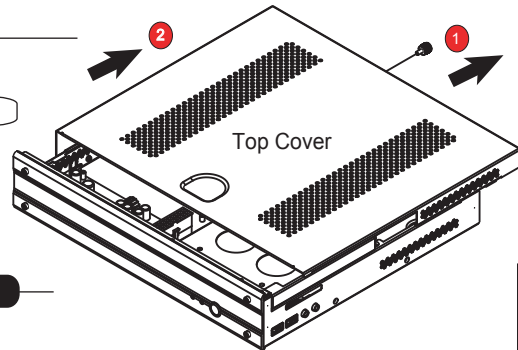

2. Remove Media Drive Filler Panel

1. Remove screws "B" (x2)
2. Remove the Filler Panel

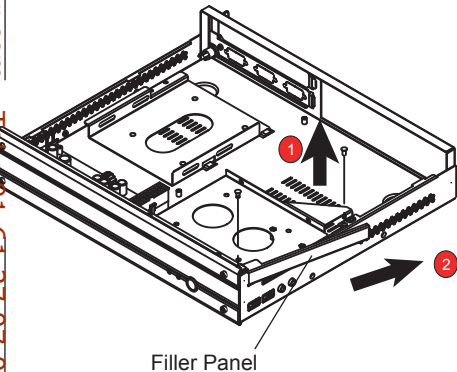

3. Remove Media Drive Holder

1. Remove screws "B" (x3)
2. Remove Media Drive Holder

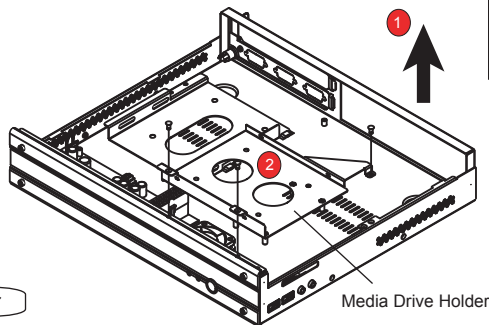

4. Install Media Drive and Compact Flash

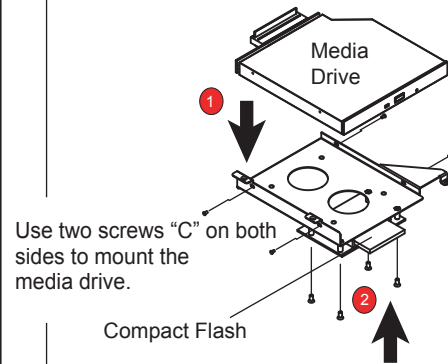

Use two screws "C" on both sides to mount the media drive.

1. Install Media drive by placing it into the Holder using screws "C" (x4)
2. Install Compact Flash with screw "B" (x4) as shown

6. Install 3.5" Hard Drive

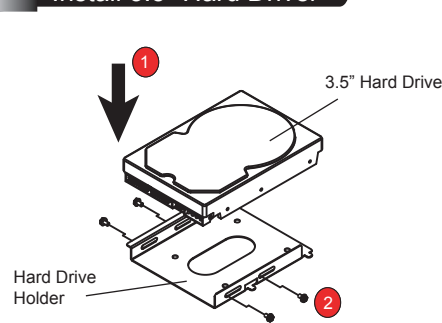

1. Place 3.5" hard drive into the holder
2. Install two screws "G" on each side

8. Install Mounting kit

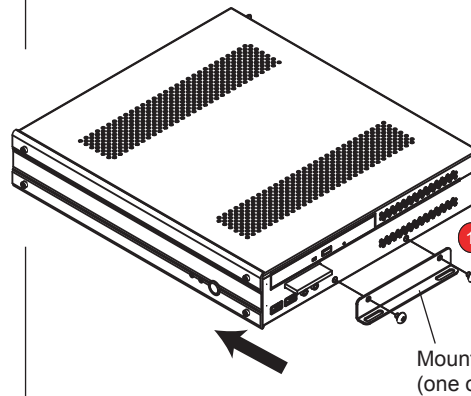

Mounting Kit
(one on each side)

5. Remove Hard Drive Holder

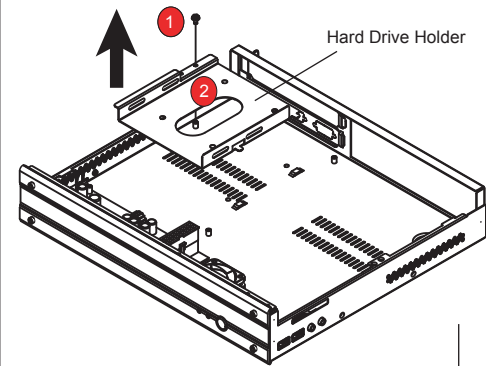

1. Remove screw "E" (x1)
2. Remove HDD Holder as shown

7. Install motherboard and PCI Card

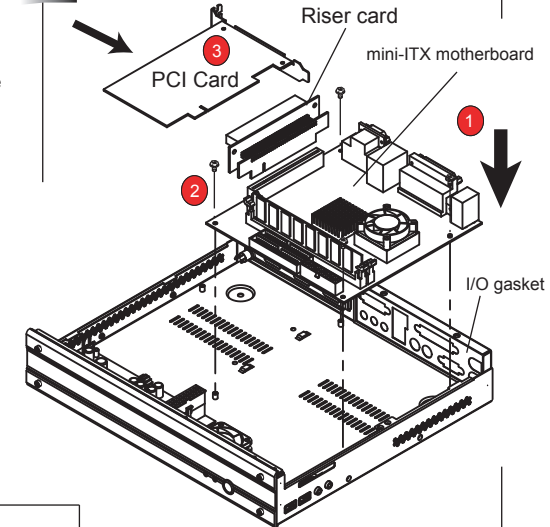

1. Place mini-ITX motherboard into the case
2. Install screws "E" (x4) as shown
3. Install the riser card and PCI card as shown

1. Attach the Mounting Bracket as shown
2. Install screws "F" (x2)
3. Repeat steps 1 & 2 on the other side of the case