



Travla Series
Model : C159 (AC POWER)
1U 10 INCH Flex ATX POWER
mini-ITX RACKMOUNT CHASSIS
QUICK START

WARNING: Installation and service of this product should only be performed by qualified personnel to avoid damage to this product and risk of injuries.

1. Remove Top Cover

- 1. Loosen 2 flat head screws
- 2. Slide Top Cover towards rear

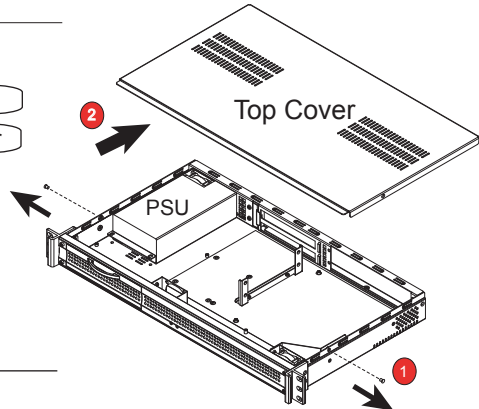

2. Install I/O Gasket

- 1. Attach I/O Gasket to "Rear Panel"
- 2. Install I/O Gasket with 4 screws

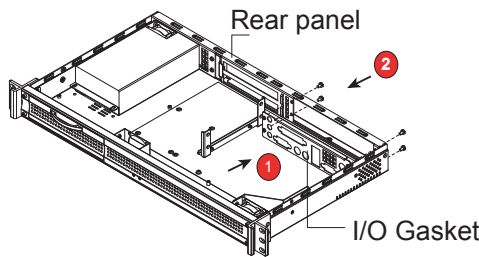

3. Install Motherboard

- 1. Place motherboard into the chassis
- 2. Install 4 hex head screws

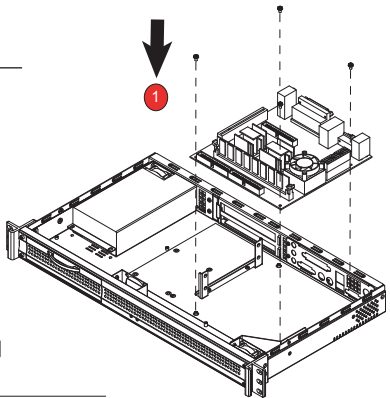

4. Install EVA form

- 1. Locate EVA form next to CPU fan

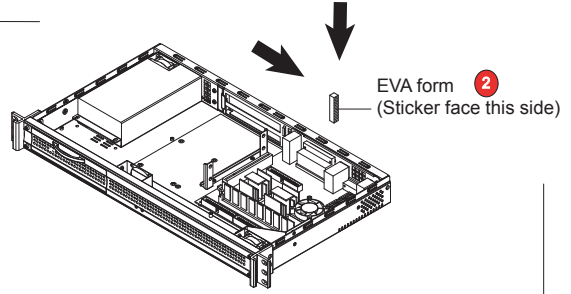
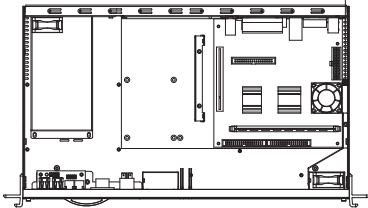

- 1. Locate "EVA form" next to CPU fan
- 2. Stick "EVA form" onto the chassis wall

5. Install 2.5" HDD

- 1. Attach 2.5" HDD onto the chassis
- 2. Install 4 flat head screws from bottom

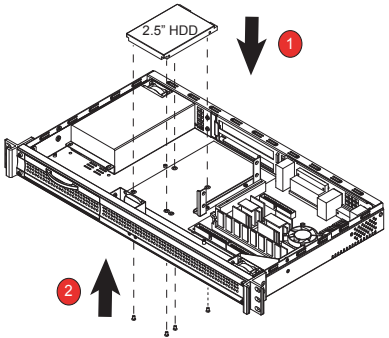

6. Install CF Reader

- 1. Install 2 spacers with 2 flat head screws
- 2. Install 2 hex head screw from top

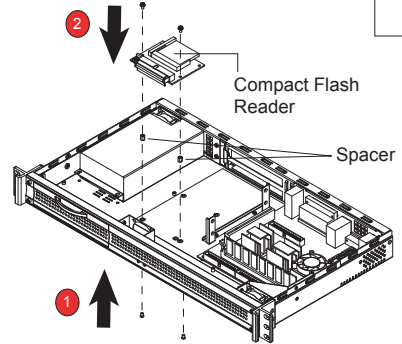

7. Install dual-PCI Riser Card

- 1. Install "dual-PCI riser card" with 4 screws

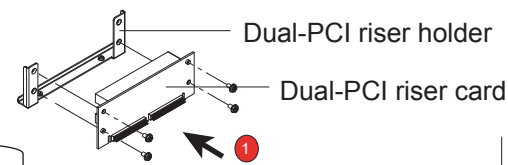

Distribue par Anteor - www.anteor.com - Tel : 01 61 37 07 00