

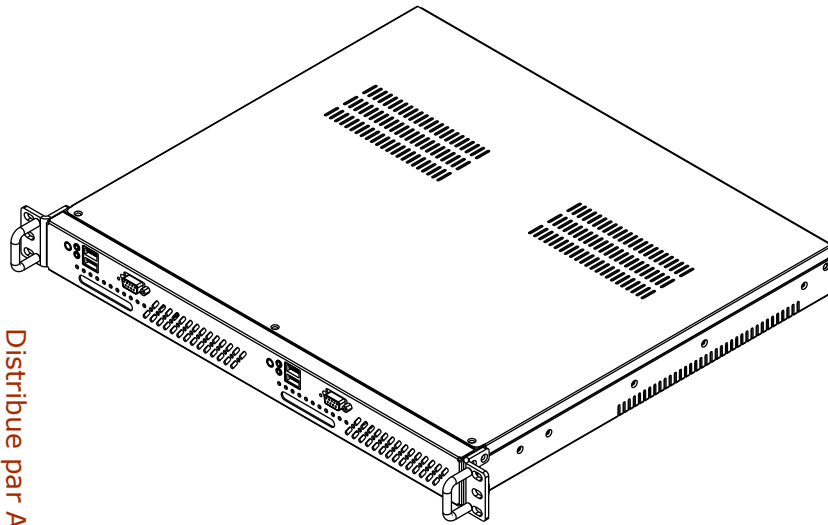

Travla C147
1U 15 INCH DUAL-MOTHERBOARD
mini-ITX RACKMOUNT CHASSIS
QUICK START
USER GUIDE



Distribue par Anteor - www.anteor.com Tel : 01 61 37 07 00

1. Remove top cover

Remove screw "A" (x3)

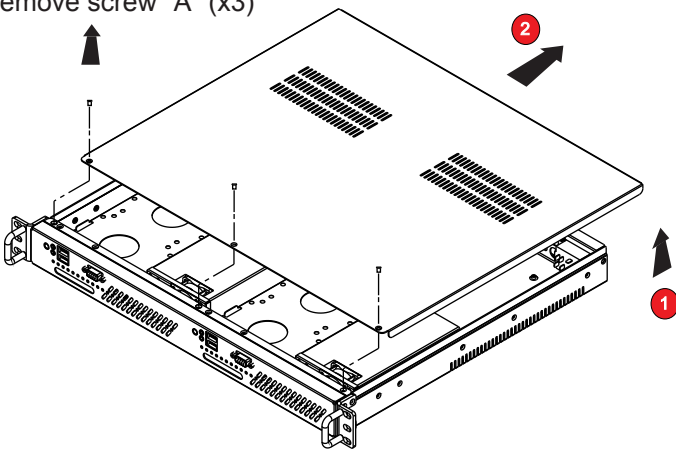

1. Lift cover upward

2. Slide top cover to rear

Screw Identification Guide

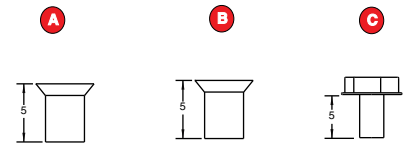

- A. Flat head screw #6-5mm
- B. Flat head screw M3-5mm
- C. Hex head screw #6-5mm

Index

- 1) Remove Top Cover
- 2) Install 3.5" HDD to drive bay holder
- 3) Install compact flash to drive bay holder
- 4) Install 2.5" HDDs to drive bay holder
- 5) Install drive bay holder with 2.5" HDDs to 1U chassis
- 6) Install drive bay holder with 3.5" HDDs to 1U chassis
- 7) Install motherboards to 1U chassis

Front Connectors

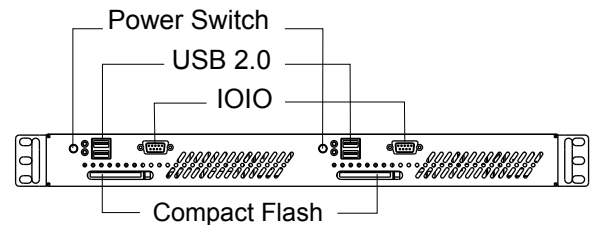

Rear Connectors

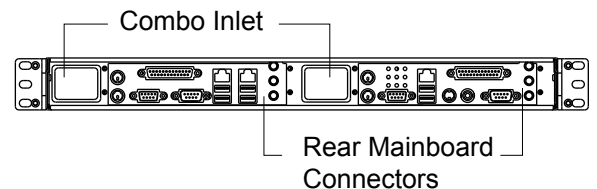

WARNING: Install and service to this product is performed only by qualified personnel to avoid risk of injuries.

2. Install 3.5" HDD to drive bay holder

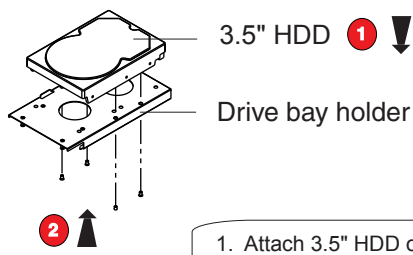

1. Attach 3.5" HDD on top of the drive bay holder

2. Install screw "A" (x4)

3. Install compact flash to drive bay holder

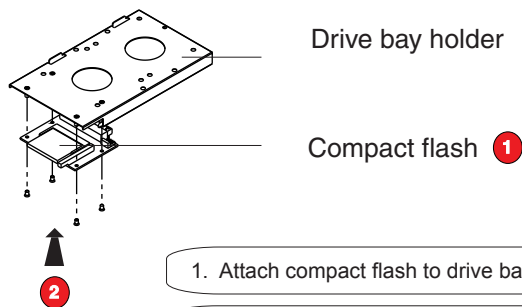

1. Attach compact flash to drive bay holder

2. Install screw "B" (x4)

4. Install 2.5" HDDs to drive bay holder

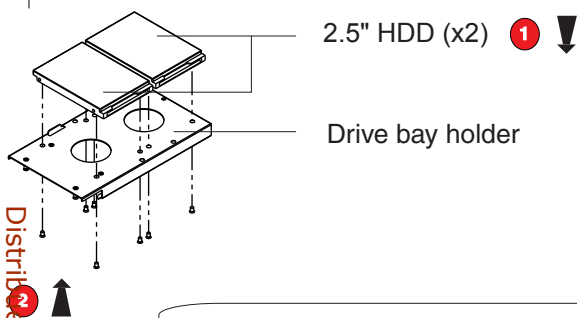

1. Attach 2.5" HDDs on top of the drive bay holder

2. Install screw "B" (x8)

5. Install drive bay holder with 2.5" HDDs to 1U chassis

Note: view without front panel

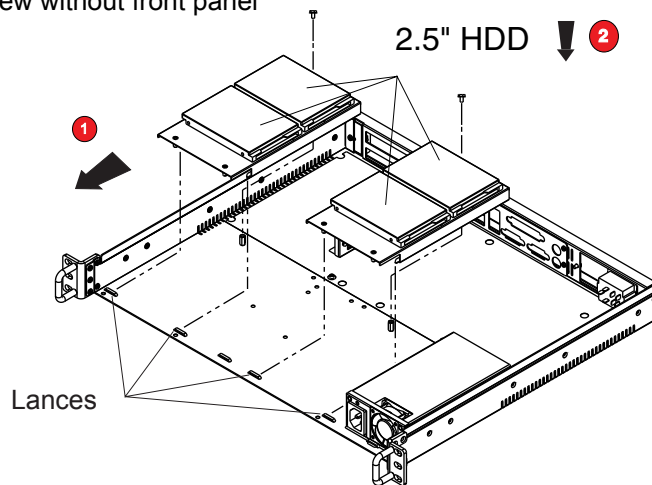

1. Slide each drive bay holder into lances as shown above

2. Install screw "C" (x2)

6. Install drive bay holder with 3.5" HDDs to 1U chassis

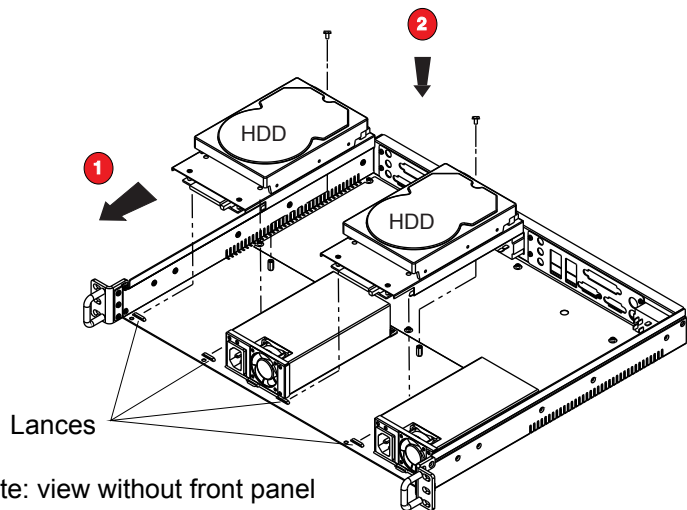

Note: view without front panel

1. Slide each drive bay holder into lances as shown above

2. Install screw "C" (x2)

7. Install motherboards to 1U chassis

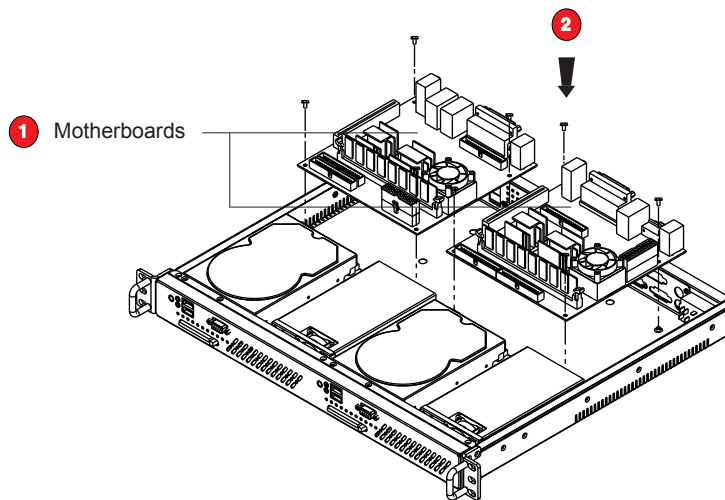

1. Place motherboards onto 1U chassis with the right I/O gasket

2. Install screw "C" (x8)