



# ART101



## ► Features

- 10.1" capacitive touch screen
- Built-in dual cameras - front: 2M, rear: 5M (auto focus & flash light)
- Android 4.2 operating system
- Supports Accelerometer, E-compass, and Gyro sensor
- Built-in Wi-Fi, BT4.0, GPS, and optional 3G support
- Built-in NFC RFID and optional 1D/2D barcode reader
- IP65 protection, 3.28ft drop tested
- Light weight, 950g



## ► I/O Connectors



## ► Dimensions

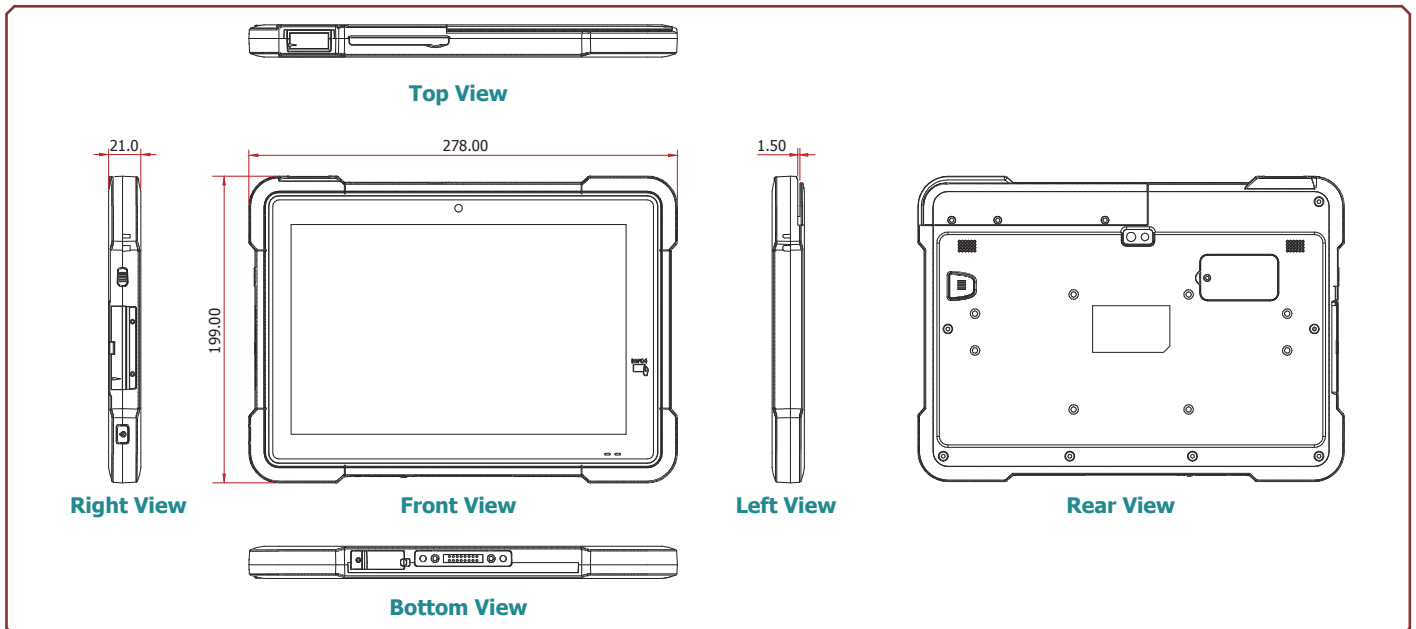

## ► Specifications

<b>SYSTEM</b>	<b>Processor</b>	Freescale i.MX 6 DualLite at 1GHz	
	<b>Memory</b>	1GB DDR3 Onboard (default)	
<b>DISPLAY AND TOUCH SCREEN</b>	<b>Display</b>	10.1" 1280x800 TFT LCD Panel with Capacitive Touch Screen	
	<b>Brightness</b>	350 cd/m <sup>2</sup>	
	<b>Sensor</b>	Accelerometer Sensor	Vibrator
		E-Compass Sensor	Light Sensor
	Gyroscope Sensor		
<b>STORAGE</b>	<b>eMMC</b>	8GB eMMC Onboard (also for Android OS image)	
<b>COMMUNICATION</b>	<b>Wireless</b>	Wi-Fi 802.11 a/b/g/n	WWAN 3G (optional)
		Bluetooth V4.0+HS	GPS (Ublox inside)
		NFC RFID 13.56MHz (ISO 14443 A/B, FeliCa)	
<b>CAMERA</b>	<b>Rear Camera</b>	5.0 Mega Pixels, Auto Focus, Flash Light	
	<b>Front Camera</b>	2.0 Mega Pixels	
<b>AUDIO</b>	<b>Internal</b>	2 x 0.8W Speaker	
<b>LED</b>	<b>Indicator</b>	1 x Red/Green LED for Power and System Status	
		1 x Blue LED for NFC RFID	
<b>I/O</b>	<b>External</b>	1 x microSD	
		1 x micro HDMI	
		1 x Earphone & Mic	
		1 x micro USB	
		1 x POGO Pins	
		1 x DC Jack	
		<b>Buttons</b>	1 x Power Button
			2 x Volume Button
		2 x Scanner Trigger Button	
	<b>POWER</b>	<b>AC/DC Adapter</b>	Input: 100~240V AC 50/60Hz 0.8A      Output: 5V DC 3A, AC Cable
<b>Battery</b>		Li-ion, 3.7V, 8060mAh Working Time: 8 hrs, Note: Wi-Fi & BT ON and LCD ON (default brightness) with Stand by Mode	
<b>OS SUPPORT</b>		Android 4.2.2 (2.5GB)	
<b>MECHANISM</b>	<b>IP Rating</b>	IP65 Protection (w/o 1D/2D barcode reader)    IP54 Protection (w/ 1D/2D barcode reader)	
	<b>Dimensions ( W x H x D )</b>	278mm x 199mm x 21mm (10.94" x 7.83" x 0.83")	
	<b>Weight</b>	950 g	
<b>ENVIRONMENT</b>	<b>Operating Temperature</b>	0 to 40°C	
	<b>Storage Temperature</b>	-20 to 60°C (w/o battery)	
	<b>Charging Temperature</b>	0 to 40°C	
	<b>Relative Humidity</b>	5 to 95% RH (non-condensing)	
<b>STANDARDS AND CERTIFICATIONS</b>	<b>Drop</b>	3.28ft Drop Tested	
	<b>Certification</b>	CE, BSMI, FCC, FCC ID: E5YART101, NCC	

## ► Ordering Information

Model Name	P/N	Configuration
<b>ART101-i6</b>	<b>790-ART101-000G</b>	Freescale i.MX 6 DualLite, DDR3 1G, eMMC 8GB, 10.1" 1280x800, Camera Front 2M, Rear 5M, Wi-Fi/BT, GPS, NFC RFID Reader, Android 4.2.2, Adapter, USB Cable, w/o Power Cord
<b>ART101-i6 + 2D BCH</b>	<b>790-ART101-100G</b>	Freescale i.MX 6 DualLite, DDR3 1G, eMMC 8GB, 10.1" 1280x800, Camera Front 2M, Rear 5M, Wi-Fi/BT, GPS, NFC RFID Reader, Android 4.2.2, Adapter, USB Cable, 2D Barcode Reader, w/o Power Cord
<b>ART101-i6 + 3G + 2D BCH</b>	<b>790-ART101-200G</b>	Freescale i.MX 6 DualLite, DDR3 1G, eMMC 8GB, 10.1" 1280x800, Camera Front 2M, Rear 5M, Wi-Fi/BT, GPS, NFC RFID Reader, 3G, Android 4.2.2, Adapter, USB Cable, 2D Barcode Reader, w/o Power Cord

\*The ART101 industrial tablet PC is not compatible with DFI's revision control system.

## ► Optional Accessories



## ► Packing List

• 1 ART101 Tablet
• 1 Power Adapter
• 1 USB Cable
• 1 Quick Guide

## ► Optional Items

• Desk Docking (w/o AC adapter)	612-CRA101-000G
• Hand Strap	622-070010-000G
• Power Cord (Europe)	A81-004003-000G
• Power Cord (USA)	332-700010-201G
• Power Cord (China)	A81-000001-000G