

# Nuvo-7160GC Series

Ruggedized GPU-Computing Platform Supporting 120W NVIDIA® GPU and Intel® 8th-Gen Core™ Processor



CE FC

## Key Features

- Supports NVIDIA® GPU graphics card up to 120W TDP
- Patented thermal design to allow -25°C to 60°C wide-temperature operation
- Intel® 8th-Gen Core™ hexa-core 35W/ 65W LGA1151 CPU
- 6x GigE ports, supporting 9.5 KB jumbo frame
- M.2 2280 M key socket (Gen3 x4) supporting NVMe SSD or Intel® Optane™ memory
- 4x USB 3.1 Gen2 ports and 4x USB 3.1 Gen1 ports
- Accommodates two 2.5" SATA HDD/ SSD with RAID 0/ 1 support
- Compatible with MeziO™ interface for function expansion
- Patented ventilation design\* for graphics card

\*R.O.C Patent No. M534371/ M456527

## Introduction

Nuvo-7160GC is a ruggedized GPU-aided edge computer designed for modern machine learning applications such as autonomous driving, facial recognition and machine vision. It supports up to a 120W GPU, delivering 4~6 TFLOPS computing power for inference, as well as Intel® 8th-Gen Core™ 6-core/ 12-thread CPU, offering up to 50% CPU performance enhancement over previous generations.

Thanks to Neosys' patented Cassette design and ingenious ventilation mechanism, Nuvo-7160GC can effectively dissipate the heat generated by the GPU. By introducing the guided airflow from intake to exhaust with powerful fans featuring smart fan control, it allows a 120W GPU to operate at 60°C ambient temperature under 100% GPU loading.

Nuvo-7160GC incorporates rich I/O functions such as USB 3.1 Gen2/ Gen1, GbE, COM and MeziO™ interface in its restricted footprint. It also leverages cutting-edge M.2 NVMe SSD technology for over 2000MB/s disk read/ write speed or Intel® Optane™ memory for the ultimate system acceleration. Neosys Nuvo-7160GC is the ideal solution for emerging edge computing by combining exceptional CPU and GPU performances.

## Specifications

System Core		Internal Expansion Bus	
Processor	Supporting Intel® 8th-Gen Coffee Lake CPU (LGA1151 socket, 35W/ 65W TDP) - Intel® Core™ i7-8700/ i7-8700T - Intel® Core™ i5-8500/ i5-8500T - Intel® Core™ i3-8100/ i3-8100T - Intel® Pentium® G5400/ G5400T - Intel® Celeron® G4900/ G4900T	PCI/PCI Express	1x PCIe x16 slot@Gen3, 16-lanes PCIe signals in Cassette for installing an NVIDIA® graphics card up to 120W TDP (Max. graphics card dimension is 188 mm(L) x 121 mm(W), dual slot allocation)
Chipset	Intel® Q370 Platform Controller Hub	Mini PCI Express	1x full-size mini PCI Express socket with internal SIM socket (mux with mSATA)
Graphics	Integrated Intel® UHD Graphics 630	M.2	1x M.2 2242 B key socket with dual front-accessible SIM sockets, supporting dual SIM mode with selected M.2 LTE module
Memory	Up to 32 GB DDR4 2666/ 2400 SDRAM (two SODIMM slots)	Expandable I/O	1x MeziO™ expansion port for Neosys MeziO™ modules
AMT	Supports AMT 12.0	<b>Power Supply</b>	
TPM	Supports TPM 2.0	DC Input	1x 3-pin pluggable terminal block for 8~35VDC DC input
<b>I/O Interface</b>		Remote Ctrl. & LED Output	1x 3-pin pluggable terminal block for remote control and PWR LED output
Ethernet	6x Gigabit Ethernet ports by I219 and 5x I210	<b>Mechanical</b>	
PoE+	Optional IEEE 802.3at PoE+ PSE for Port 3 ~ Port 6 100 W total power budget	Dimension	240 mm (W) x 225 mm (D) x 111 mm (H)
USB	4x USB 3.1 Gen2 (10 Gbps) ports 4x USB 3.1 Gen1 (5 Gbps) ports	Weight	4.5 Kg (including CPU, GPU, memory and HDD)
Video Port (Integrated Graphics)	1x VGA connector, supporting 1920 x 1200 resolution 1x DVI-D connector, supporting 1920 x 1200 resolution 1x DisplayPort connector, supporting 4096 x 2304 resolution	Mounting	Wall-mounting (standard) or DIN-Rail mounting (optional)
Serial Port	2x software-programmable RS-232/422/485 ports (COM1/ COM2) 2x RS-232 ports (COM3/ COM4)	<b>Environmental</b>	
Audio	1x 3.5 mm jack for mic-in and speaker-out	Operating Temperature	With 35W CPU and 120W GPU -25°C ~ 60°C ** With 65W CPU and 120W GPU -25°C ~ 60°C ***/** (configured as 35W TDP) -25°C ~ 50°C ***/** (configured as 65W TDP)
<b>Storage Interface</b>		Storage Temperature	-40°C ~ 85°C
SATA HDD	2x internal SATA port for 2.5" HDD/ SSD installation, supporting RAID 0/ 1	Humidity	10%~90%, non-condensing
M.2	1x M.2 2280 M key socket (PCIe Gen3 x4) for NVMe SSD or Intel® Optane™ memory installation	Vibration	Operating, MIL-STD-810G, Method 514.6, Category 4
mSATA	1x full-size mSATA port (mux with mini-PCIe)	Shock	Operating, MIL-STD-810G, Method 516.6, Procedure I, functional shock=50g
		EMC	CE/FCC Class A, according to EN 55032 & EN 55024

\*\* For i7-8700 running at 65W mode, the highest operating temperature shall be limited to 50°C and thermal throttling may occur when sustained full-loading applied. Users can configure CPU power in BIOS to obtain higher operating temperature.

\*\*\* For sub-zero operating temperature, a wide temperature HDD or Solid State Disk (SSD) is required.

## Appearance

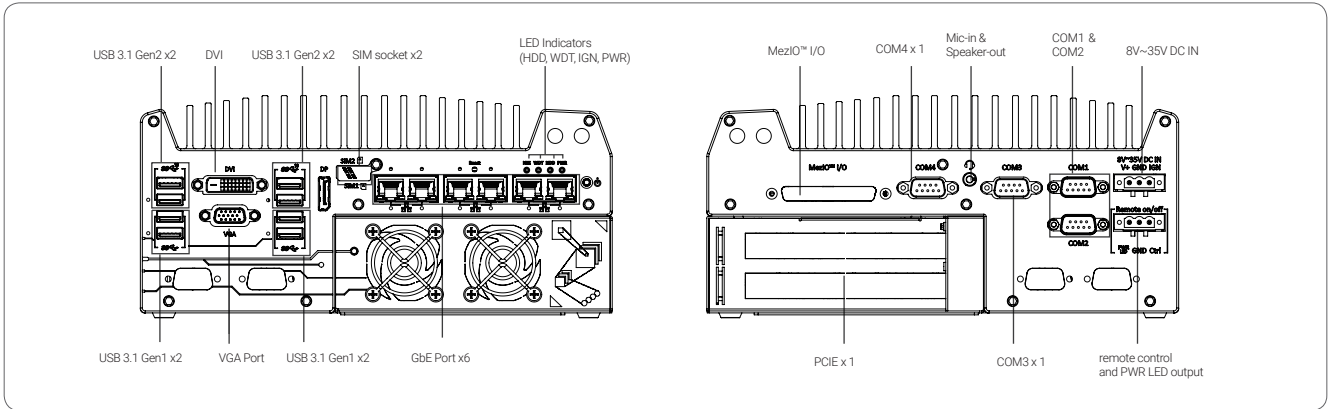

## Dimensions

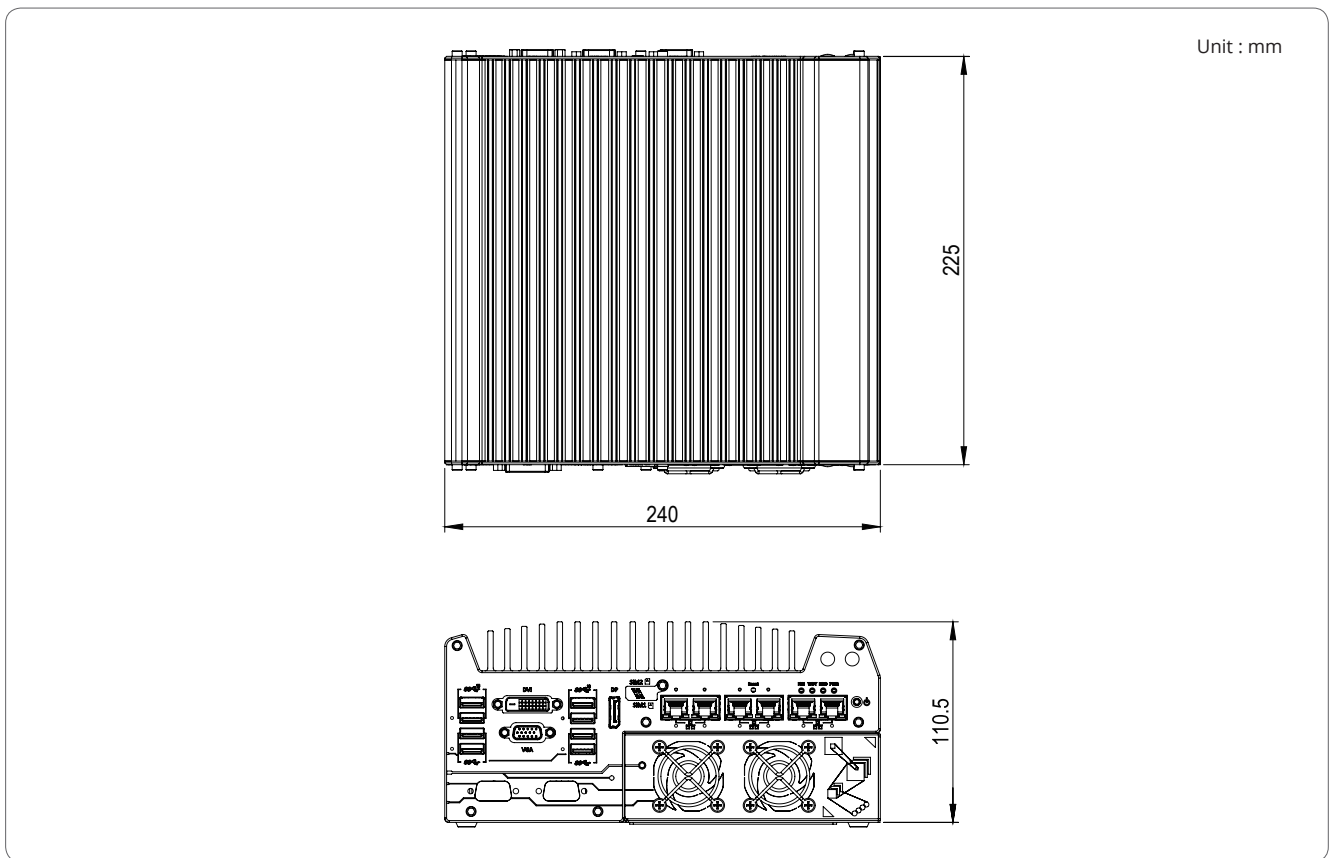

## Ordering Information

Model No.	Product Description
Nuvo-7160GC	Intel® 8th-Gen Core™ GPU-computing platform with 6x GbE and MeziO™, supporting selected NVIDIA® 120W GPU
Option of 802.3at PoE+ for GbE ports 3 ~ 6	

## Optional Accessories

PA-280W-OW	280W AC/DC power adapter 24V/11.67A; 16AWG/100cm; Cord end terminals for terminal block, operating temperature : -30°C to 60°C.
------------	---